

符合"DLK环境管理物质技术标准"

符合USB3.0协会规范标准"

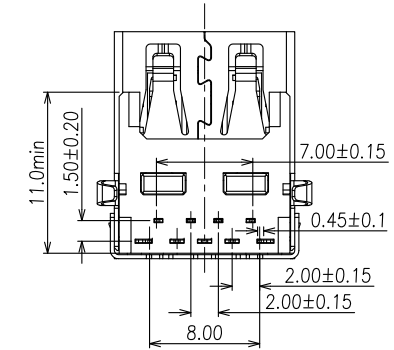
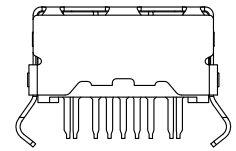
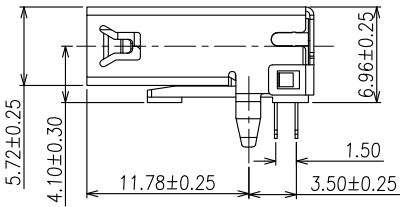
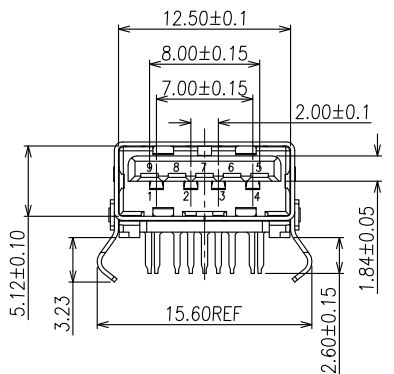
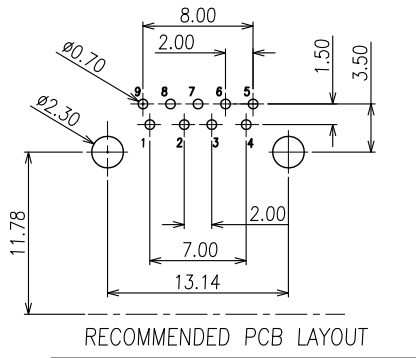
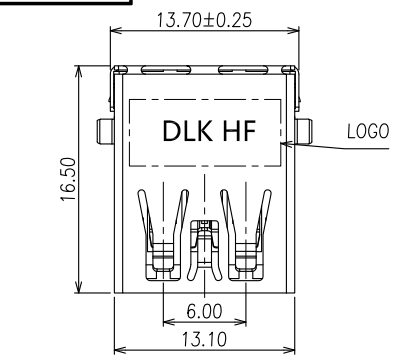

NOTE:

1. MATERIAL:
 - 1.1 Housing: LCP UL94v-0, color: Black
 - 1.2 Contact: Phosphor bronze
 - 1.3 Shell: Stainless steel
2. PLATING:
 - 2.1 Contact: 15u" Au plated on contact Area,50u" Min. Matte Tin plated on solder tail,50u" Min. Nickel underplated
 - 2.2 Shell: Nickel plated overall
3. MECHANICAL:
 - 3.1 Mating force:3.57kgf Max.
 - 3.2 Unmating force:1.02kgf Min.
 - 3.3 Durability:1500 cycles Min.
4. ELECTRICAL:
 - 4.1 Current Rating:1.5A
 - 4.2 Voltage Rating:36V
 - 4.3 Dielectric strength:500V AC FOR 1 minute
 - 4.4 Insulation Resistance:1000MΩ Min.
 - 4.5 Contact Resistance:30mΩ Max
5. Operating Temperature:-55°c to +85°c
6. PACKING: Tray

工程变更通知单 ECN(DCN) NO.	版本 REV	日期 DATE	说明 DESCRIPTION	变更 CHANGE	核准 APPRO.
KSECN17043	A	20170725	NEW RELEASE	—	—
KSECN23026	B	20231220	模具老化, 产品结构变更 Δ *1	J Z	Roy

GENERAL TOLERANCE UNLESS OTHERWISE NOTED	
Angle	±5°
X.	±0.35
.X	±0.25
.XX	±0.15
.XXX	±0.10

 德力康电子科技有限公司
DLK DELIKANG ELECTRONICS TECHNOLOGY CO.,LTD

C 名称 TITLE:	USB 3.0 A/F R/A 6.96H STD.			
档案名称 FILE NAME:	C-U3A20-00-0E	料号 PART NO:	22009B042E1	
DRAWING	W Y H	CHECKED	APPROVED	Y C W
UNIT:	mm	SCALE	1:1	SHEET: 1 of 1

NO.	ITEM	Q'TY	DESCRIPTION	FINISH
4	COVER	1	LCP	UL94V-0
3	CONTACT	9	Phosphor bronze	Au PLATED
2	SHELL	1	Stainless steel	Ni PLATED
1	HOUSING	1	LCP	UL94V-0