

符合"DLK 环境管理物质技术标准"

符合USB3.0协会规范标准"

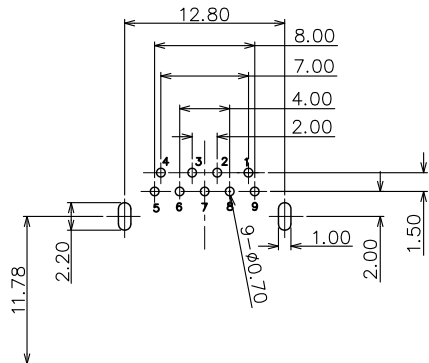

RECOMMENDED PCB LAYOUT
TOLERANCE: ±0.05mm

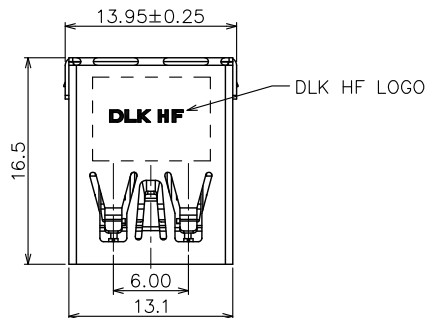
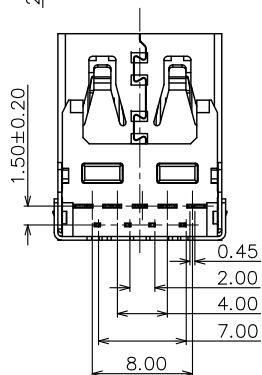
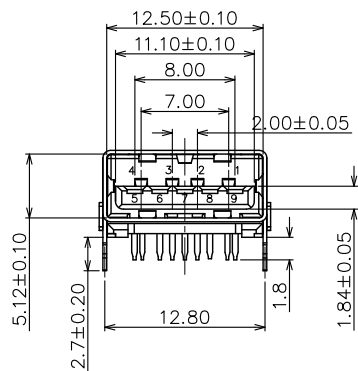
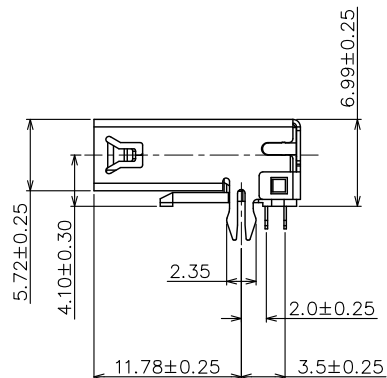

工程变更通知单 ECN(DCN) NO.	版本 REV	日期 DATE	说明 DESCRIPTION	变更 CHANGE	核准 APPRO.
KSECN24006	A	20240314	NEW RELEASE	—	—

NOTE:

1. MATERIAL.

1.1 Housing: LCP UL94v-0, color: Black

1.2 Contact: Phosphor bronze

1.3 Shell: Stainless steel

2. PLATING:

2.1 Contact: 30u" Au plated on contact Area,50u" Min. Matte Tin plated on solder tail,50u" Min. Nickel underplated

2.2 Shell: Nickel plated overall

3. MECHANICAL:

3.1 Mating force: 3.57kgf Max.

3.2 Unmating force: 1.02kgf Min.

3.3 Durability: 1500 cycles Min.

4 ELECTRICAL:

4.1 Current Rating: 1.5A

4.2 Voltage Rating: 36V

4.3 Dielectric strength: 500V AC FOR 1 minute

4.4 Insulation Resistance: 1000MΩ Min.

4.5 Contact Resistance: 30mΩ Max

5. Operating Temperature: -55°C to +85°C

6. PACKING: Tray

GENERAL TOLERANCE
UNLESS OTHERWISE NOTED

Angle	±5°
X.	±0.35
.X	±0.25
.XX	±0.15
.XXX	±0.10



德力康电子科技有限公司
DLK DELIKANG ELECTRONICS TECHNOLOGY CO.,LTD

C 名称 TITLE:	USB 3.0 A/F R/A 6.98H RVS.			
档案名称 FILE NAME:	C-U3A20-00-3L	料号 PART NO:	22009B053L1	
DRAWING	蒋召	CHECKED	覃智森	APPROVED 段国强
UNIT:	mm	SCALE	1:1	SHEET: 1 of 1

NO.	ITEM	Q'TY	DESCRIPTION	FINISH
4	COVER	1	LCP	UL94V-0 BLACK
3	CONTACT	9	Phosphor bronze	Au PLATED
2	SHELL	1	Stainless steel	Ni PLATED
1	HOUSING	1	LCP	UL94V-0 BLACK