

符合"DLK环境管理物质技术标准",符合USB协会规范要求

工程变更通知单 ECN(DCN) NO.	版本 REV	日期 DATE	说明 DESCRIPTION	改变 CHANGE	承认 APPRO.
KSECN19059	A	20191028	NEW RELEASE	—	—
KSECN21007	B	20210326	外壳接缝增加四个焊点做加强处理	蒋召	覃智森

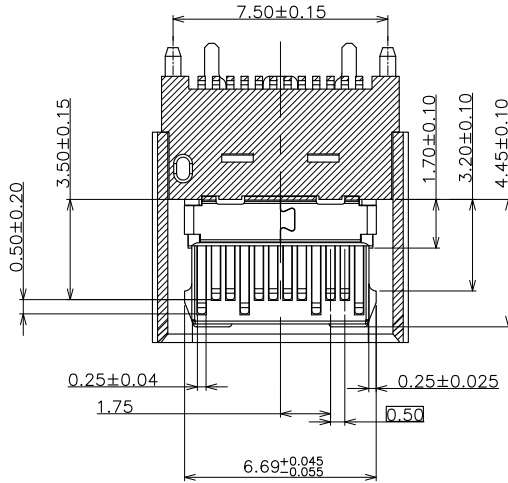

SECTION B-B
SCALE 1:1

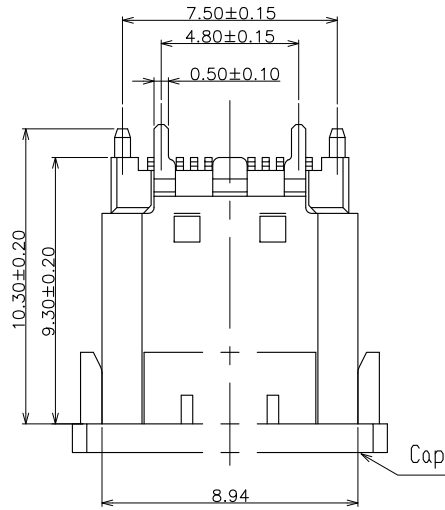
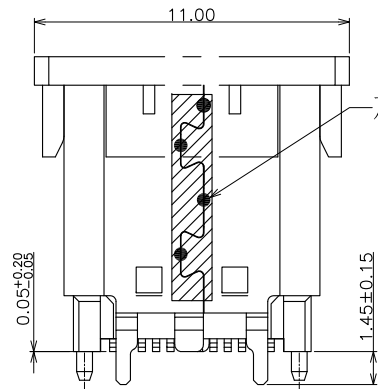
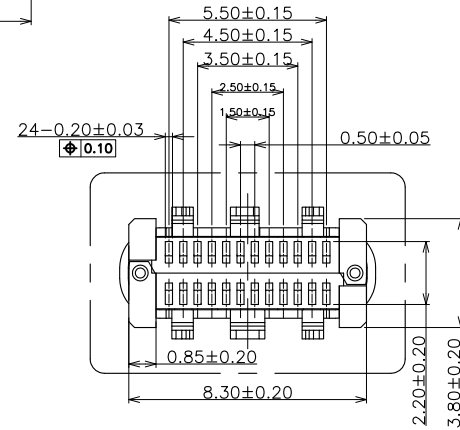
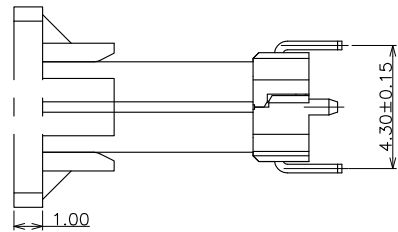
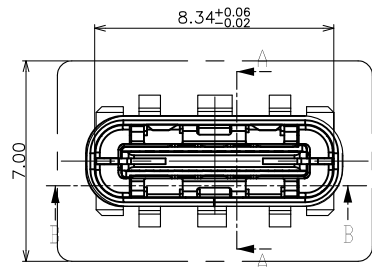

加点焊做加强处理

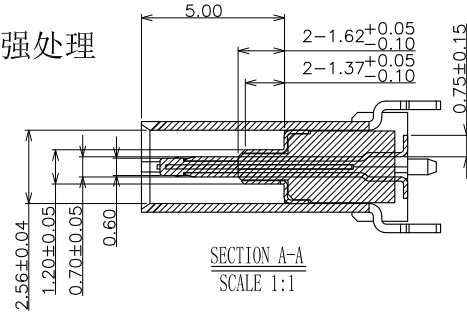

SECTION A-A
SCALE 1:1

NOTE:

- MATERIAL:
 - Housing: LCP UL94v-0, color: Black
 - Contact: Phosphor bronze
 - Shell: Stainless steel
 - EMI SHILD: Stainless steel
 - Mid Plate: Stainless steel
- PLATING:
 - Contact: G/F plated on contact Area & on solder Area, Nickel underplated
 - Shell: Nickel plated overall
- MECHANICAL:
 - Mating force:5~20N
 - Unmating force:8~20N
 - Durability:10000 cycles
- ELECTRICAL:
 - Current Rating:5A
 - Voltage Rating:48V
 - Dielectric strength:100v AC FOR 1 minute
 - Insulation Resistance:100MΩ Min.
 - Contact Resistance:40mΩ Max
- PACKING: Tape & Reel

GENERAL TOLERANCE
UNLESS OTHERWISE NOTED

Angle	±5°
X.	±0.35
.X	±0.25
.XX	±0.15
.XXX	±0.10
A4	



德力康电子科技有限公司

DLK DELIKANG ELECTRONICS TECHNOLOGY CO.,LTD

C 名称 TITLE	USB C TYPE F SMT 直立式9.30H			
档案名称 FILE NAME.	C-U3C61-00-02	料号 PART NO.	46124B01121	
DRAWING	yh.wang	CHECKED		APPROVED 严成旺
UNIT:	mm	SCALE	1:1	SHEET: 1 of 2

符合"DLK环境管理物质技术标准",符合USB协会规范要求

工程变更通知单 ECN(DCN) NO.	版本 REV	日期 DATE	说明 DESCRIPTION	改变 CHANGE	承认 APPRO.
KSECN19059	A	20191028	NEW RELEASE	—	—
KSECN21007	B	20210326	外壳接缝增加四个焊点做加强处理	蒋召	覃智森

USB TYPE-C FULL-FEATURED RECEPTACLE INTERFACE PIN ASSIGNMENTS

PIN	Signal Name	Description	PIN	Signal Name	Description
A1	GND	Ground return	B12	GND	Ground return
A2	SSTXp1	Positive half of first SuperSpeed TX differential pair	B11	SSTXp1	Positive half of first SuperSpeed TX differential pair
A3	SSTXn1	Negative half of first SuperSpeed TX differential pair	B10	SSTXn1	Negative half of first SuperSpeed TX differential pair
A4	VBUS	Bus Power	B9	VBUS	Bus Power
A5	CC1	Configuration Channel	B8	CC1	Configuration Channel
A6	Dp1	Positive half of the USB 2.0 differential pair-Position 1	B7	Dp1	Positive half of the USB 2.0 differential pair-Position 1
A7	Dn1	Negative half of the USB 2.0 differential pair-Position 1	B6	Dn1	Negative half of the USB 2.0 differential pair-Position 1
A8	RFU1	Reserved for Future Use (RFU)	B5	RFU1	Reserved for Future Use (RFU)
A9	VBUS	Bus Power	B4	VBUS	Bus Power
A10	SSRXn2	Negative half of second SuperSpeed RX differential pair	B3	SSRXn2	Negative half of second SuperSpeed RX differential pair
A11	SSRXp2	Positive half of second SuperSpeed RX differential pair	B2	SSRXp2	Positive half of second SuperSpeed RX differential pair
A12	GND	Ground return	B1	GND	Ground return

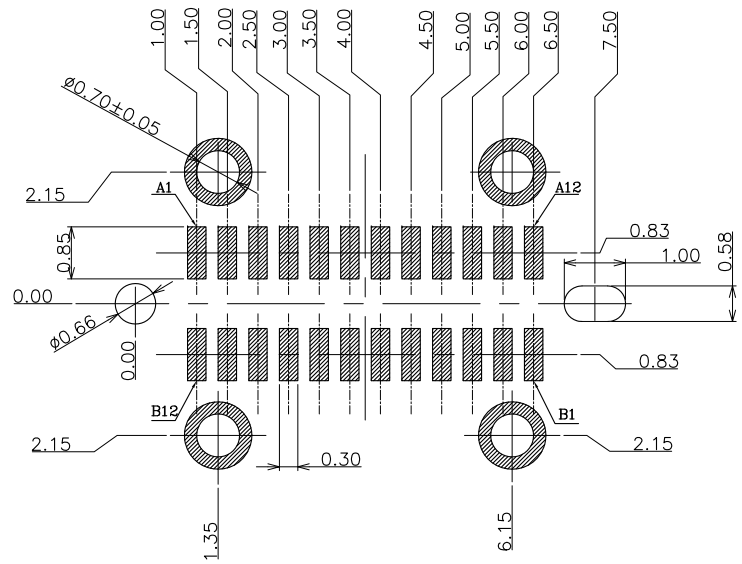

RECOMMENDED P.C.B. LAYOUT (T:1.00mm)
TOLERANCE UNSPECIFIED ±0.05mm

GENERAL TOLERANCE UNLESS OTHERWISE NOTED		德力康电子科技有限公司 DLK DELIKANG ELECTRONICS TECHNOLOGY CO.,LTD			
Angle	±5°	C 名称 TITLE USB C TYPE F SMT 直立式 9.30H			
.X	±0.35	档案名称 FILE NAME. C-U3C61-00-02		料号 PART NO.	46124B01121
.XX	±0.25	DRAWING yh.wang		CHECKED	APPROVED 严成旺
.XXX	±0.15	UNIT: mm		SCALE	1:1
A4	±0.10	SHEET: 2 of 2			